

PİRİNÇ DİŞLİ TEPE FLANŞLI KÜRESEL VANA

- Teknik Özellikleri
- Uygulama Alanları
- Teknik Detay





TKC

directs to fluid

TKC ENDÜSTRİYEL ÜRÜNLER VE
YAPI MALZEMELERİ SAN. TİC. LTD. ŞTİ

PIRİNÇ DİŞLİ TEPE FLANŞLI KÜRESEL VANA

TKC6725P



PIRİNÇ DİŞLİ TEPE FLANŞLI KÜRESEL VANA

Küresel vanalar çok açılıp kapanan veya çabuk açılıp kapanması gereken yerlerde öncelikli olarak tercih edilir. Küresel vanalar, iyi derecede sızdırmazlık özellikleri, düşük basınç kaybı sağlamaları, kolay açılıp kapanmaları ve bru hattında az yer kaplamaları sebebiyle sıklıkla tercih edilen metal vana türlerinden biridir.

UYGULAMA ALANLARI

- Su
- Atıksu
- HVAC
- Denizcilik
- Kimya
- Çimento
- Gıda
- Kondens hatlar
- Genel Endüstriyel Uygulamalar

TEKNİK ÖZELLİKLER

Gövde

Pirinç

Bağlantı

Dişli

Küre

AISI 304

Max Çalışma Basıncı

25 Bar

Max Çalışma Sıcaklığı

120°C

İkitelli O.S.B. Trios 2023 İş Merkezi B Blok Kat:3 No:143
Başakşehir / İSTANBUL

+90 212 854 05 70

info@tkc.com.tr

www.tkc.com.tr



TKC

directs to fluid



Teknik Detay / Technical Detail

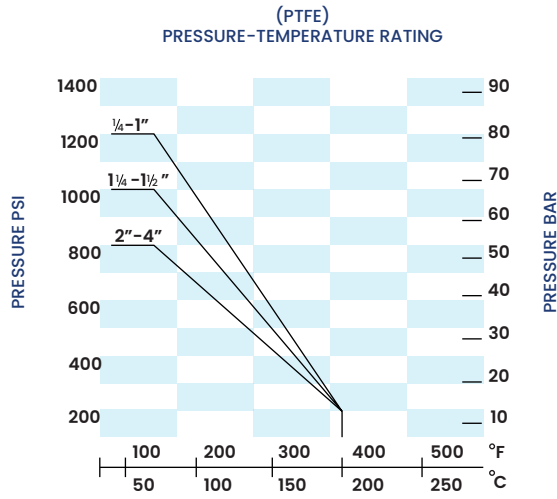
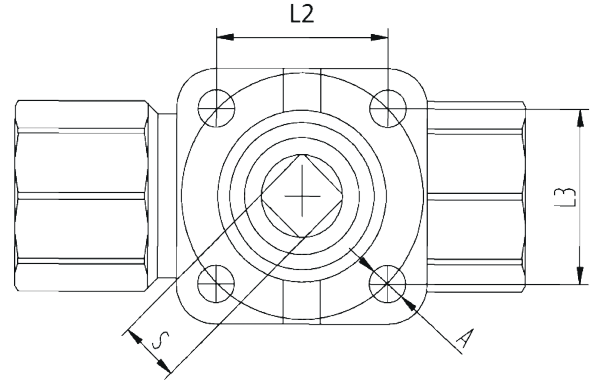
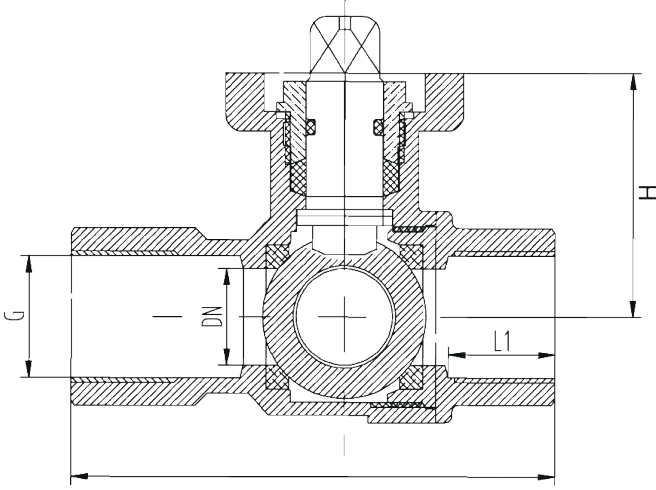

ITEM	PART NAME	MATERIAL
1	Body	CuZn40Pb2
2	Cap	CuZn40Pb2
3	Seat	PTFE/RPTFE
4	Joint Gasket	PTFE/RPTFE
5	Thrust Washer	PTFE/RPTFE
6	Packing	PTFE/RPTFE
7	Gland	S201/S304
8	Nut	S201/S304
9	Stem	CuZn40Pb2
10	Ball	CuZn40Pb2

SIZE	1/2"	3/4"	1"	1 1/4"	1 1/2"	2"	2 1/2"	3"
DN	15	20	25	32	40	50	65	80
L3	25,4	25,4	25,4	30	35	35	35	49,5
L2	25,4	25,4	25,4	30	35	35	35	49,5
L1	16,5	18,5	22	30	30	32	32	34
A	5,5	5,5	5,5	5,5	6,7	6,7	6,7	9
L	75	80	90	112	127	142,5	161	184,5
H	38	40	45	55	61	72,5	82,5	95
S	9	9	9	11	11	14	14	14

İkitelli O.S.B. Trios 2023 İş Merkezi B Blok Kat:3 No:143
Başakşehir / İSTANBUL

+90 212 854 05 70

info@tkc.com.tr

www.tkc.com.tr

TKC
directs to fluid

